

**Delta
Hydronics**

Grid Coil Heat Exchangers

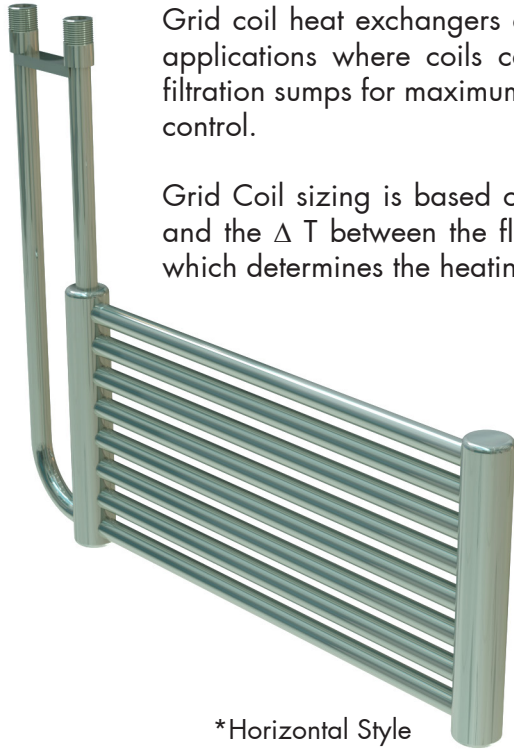

*Horizontal Style

Grid coil heat exchangers are designed for immersion heating and cooling applications where coils can be installed directly inside aquatic tanks or filtration sumps for maximum heat transfer efficiency and optimal temperature control.

Grid Coil sizing is based on the thermal conductivity of the tubing material and the ΔT between the fluid inside the coil and desired tank temperature which determines the heating surface area.

Grid coils can be used for both heating and cooling applications. Delta can configure multi-tank immersion grid coil heating and chilling systems to include all required boiler, chiller and pumping equipment.



* Vertical Style

FEATURES AND BENEFITS

- SUPERIOR CORROSION RESISTANCE
- TITANIUM & 316SS CONSTRUCTION
- VARIABLE FLOW DESIGNS
- DURABLE AND LONG SERVICE LIFE
- CUSTOM FIT TO TANK DIMENSION

DIMENSIONAL DATA

VERTICAL STYLE

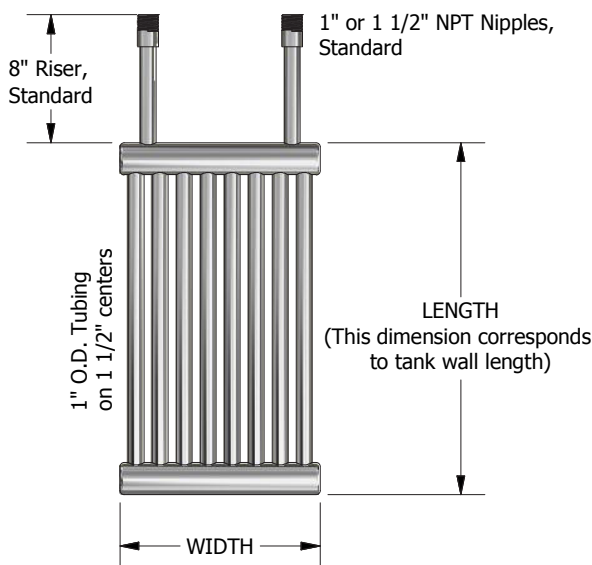

HORIZONTAL STYLE

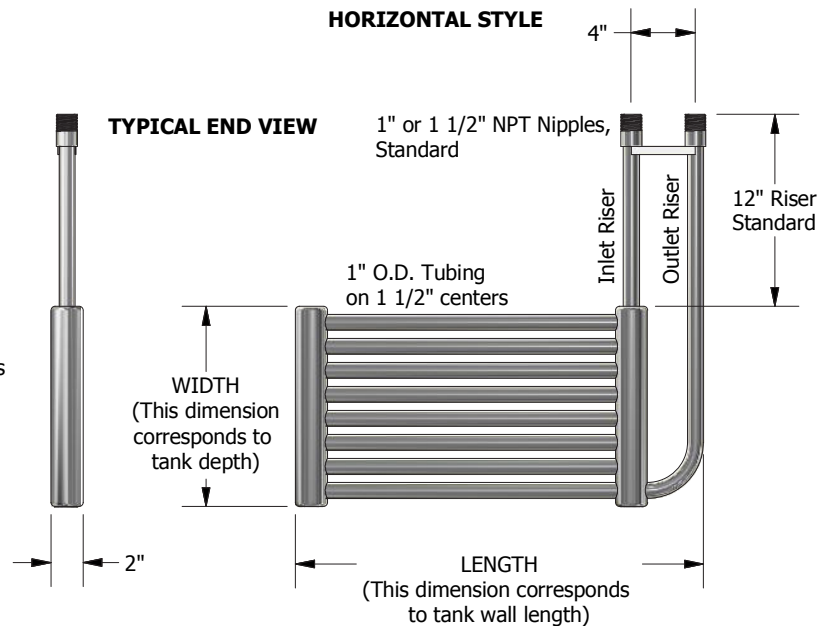

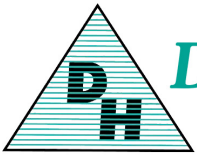

**Delta
Hydronics**

New Titanium Double Round Grid Coil



This new Titanium Double Round Grid Coil provides more heat transfer area in a smaller footprint due to its additional piping layer.



FEATURES AND BENEFITS

- SUPERIOR CORROSION RESISTANCE
- TITANIUM CONSTRUCTION
- VARIABLE FLOW DESIGNS
- DURABLE AND LONG SERVICE LIFE
- CUSTOM FIT TO TANK DIMENSION

