

# IMMERSION COIL

TITANIUM COIL FOR USE IN ALL AQUATIC CHILLING APPLICATIONS

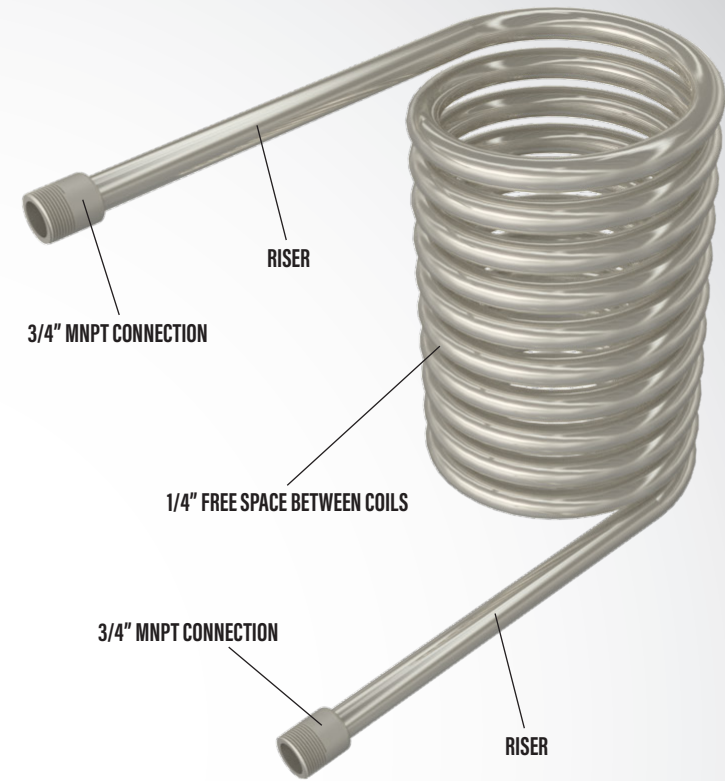
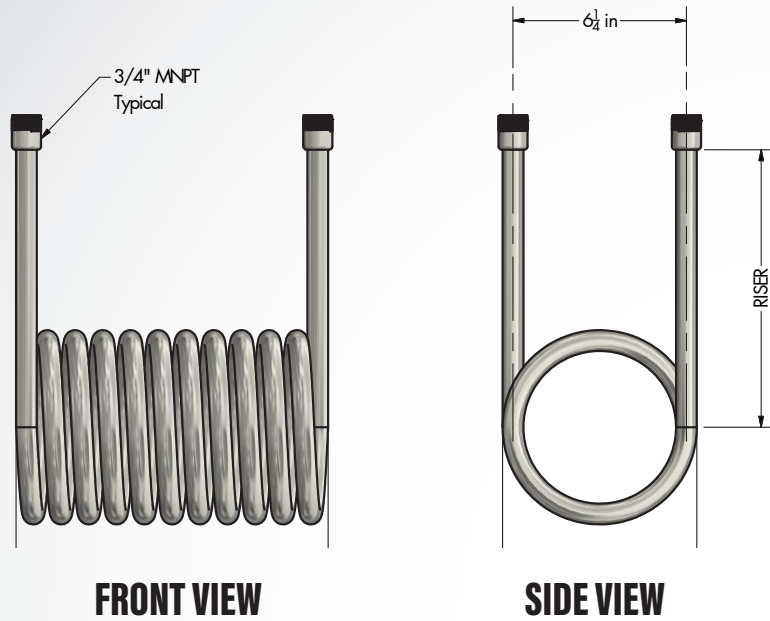

## 3/4" IMMERSION COIL - 3/4" MNPT CONNECTIONS

MODEL NUMBER	SPECIFICATIONS		DIMENSIONS					AREA SURFACE AREA (sq. ft.)	BTU's TRANSFER			FLOW GPM @ PSID <= 5
	NOMINAL LENGTH (in)	NOMINAL LENGTH (ft)	COIL OD (in)	OVERALL WIDTH (in)	COIL QUANTITY	COIL LENGTH (in)	RISER LENGTH (in)		45°F ΔT (BTU)	25°F ΔT (BTU)	15°F ΔT (BTU)	
DH-IC-.75-120	120	10	7	6.25	5.5	124	8	1.96	11,039	6,133	3,680	22
DH-IC-.75-200	200	16.66	7	10.25	9.5	206.5	10	3.27	18,391	10,217	6,130	16
DH-IC-.75-300	300	25	7	15.25	14.5	308.75	12	4.91	27,598	15,332	9,199	13
DH-IC-.75-400	400	33.33	7	20.25	19.5	406.875	12	6.54	36,793	20,441	12,264	11
DH-IC-.75-480	480	40	7	24.25	23.5	485.5	12	7.85	44,156	24,531	14,719	10
DH-IC-.75-600	600	50	7	30.25	29.5	603.25	12	9.81	55,195	30,664	18,398	8

### OPTIONS:

- CUSTOM RISER LENGTH
- CUSTOM DIAMETERS AVAILABLE FROM 5" - 12" OD



9100 Bolton Ave., Hudson, FL, 34667 (727) 861-2421 - info@deltahydro.com